

8 7 6 5 4 3 2 1

D
C
B
A

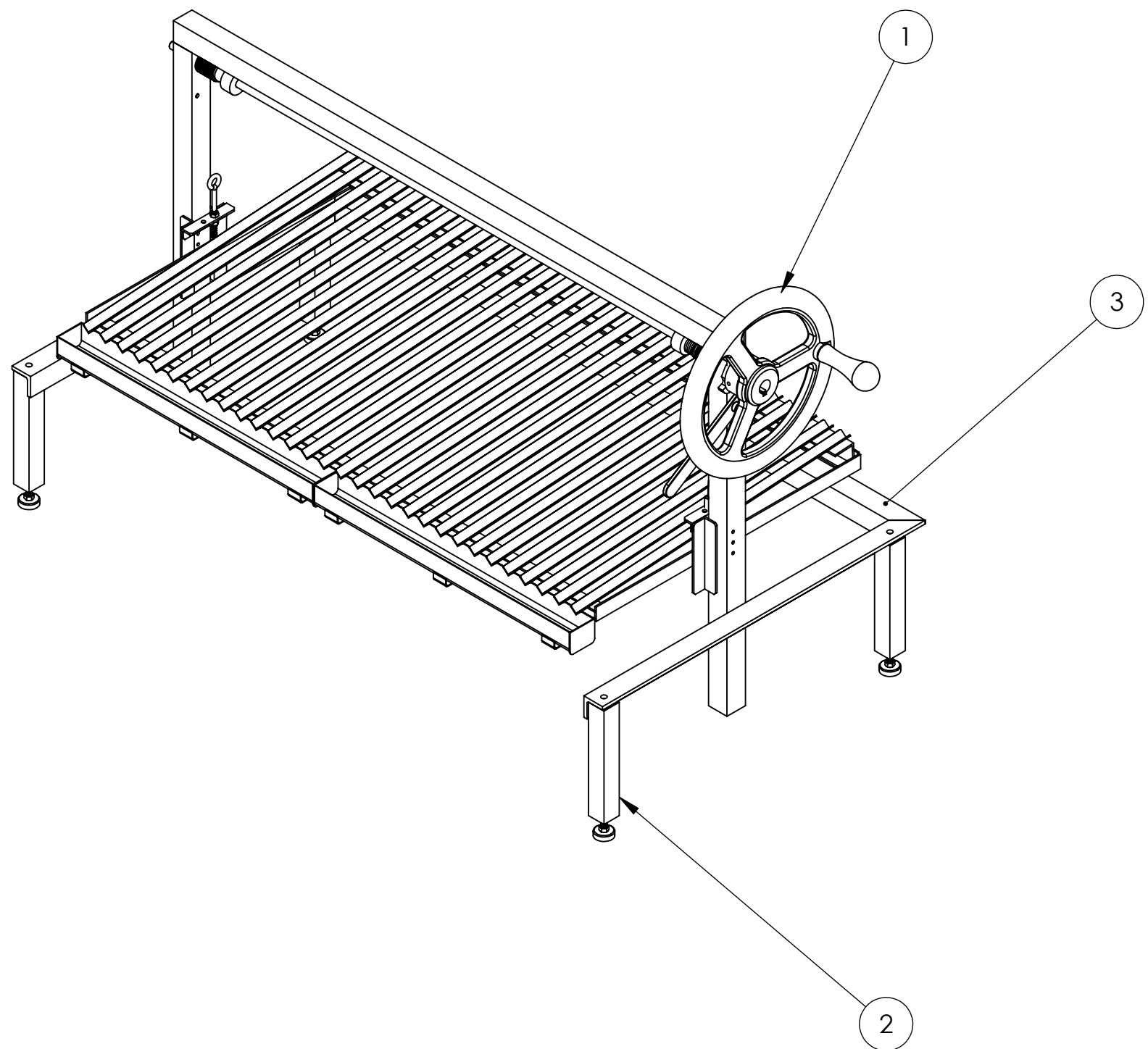

| | | | | |
|---|------------------|--|---|---|
| 3 | GP5-C | PLATFORM, LARGE | - | 1 |
| 2 | G023-9.50X1.25-2 | LEG WELDMENT, ADJUSTABLE | - | 4 |
| 1 | G014-4-2 | WHEEL ASSY, THREE SPOKE, THRU WALL, 10.00 DIA. ALUM, RH, WG & HD | - | 1 |

| ITEM NO | DRAWING NUMBER | DESCRIPTION | REV | QTY. |
|---------|----------------|-------------|-----|------|
|---------|----------------|-------------|-----|------|

UNLESS OTHERWISE SPECIFIED:

DIMENSIONS ARE IN INCHES
 TOLERANCES:
 ONE PLACE DECIMAL ±.1
 TWO PLACE DECIMAL ±.01
 THREE PLACE DECIMAL ±.005
 ANGULAR ±.5°
 SURFACE ROUGHNESS 125µin

INTERPRET GEOMETRIC TOLERANCING PER: ASME Y14.5M-1994

MATERIAL

FINISH

DO NOT SCALE DRAWING

| | | |
|--------------------------------------|------|------|
| DRAWN | NAME | DATE |
| ENG APPR. | | |
| MFG APPR. | | |
| Quantity | | |
| Heat Treatment and Special Handling: | | |

Gaucha Grills

TITLE:
 INSERT. LARGE, LEG MOUNT, RH

| | | |
|----------|----------|-----|
| SIZE | DWG. NO. | REV |
| B | GI5-4C-2 | - |

SCALE:1:1 SHEET 1 OF 2

THIS DRAWING IS THE PROPERTY OF ARGENTUM OUTDOOR CREATIONS, LLC. REPRODUCTIONS SHALL BE FOR QUOTATION, MANUFACTURING OR PURCHASING PURPOSES ONLY. RELEASE OF DRAWINGS TO OTHER CONCERNS DOES NOT CONSTITUTE LICENSING IN ANY WAY.

8 7 6 5 4 3 2 1

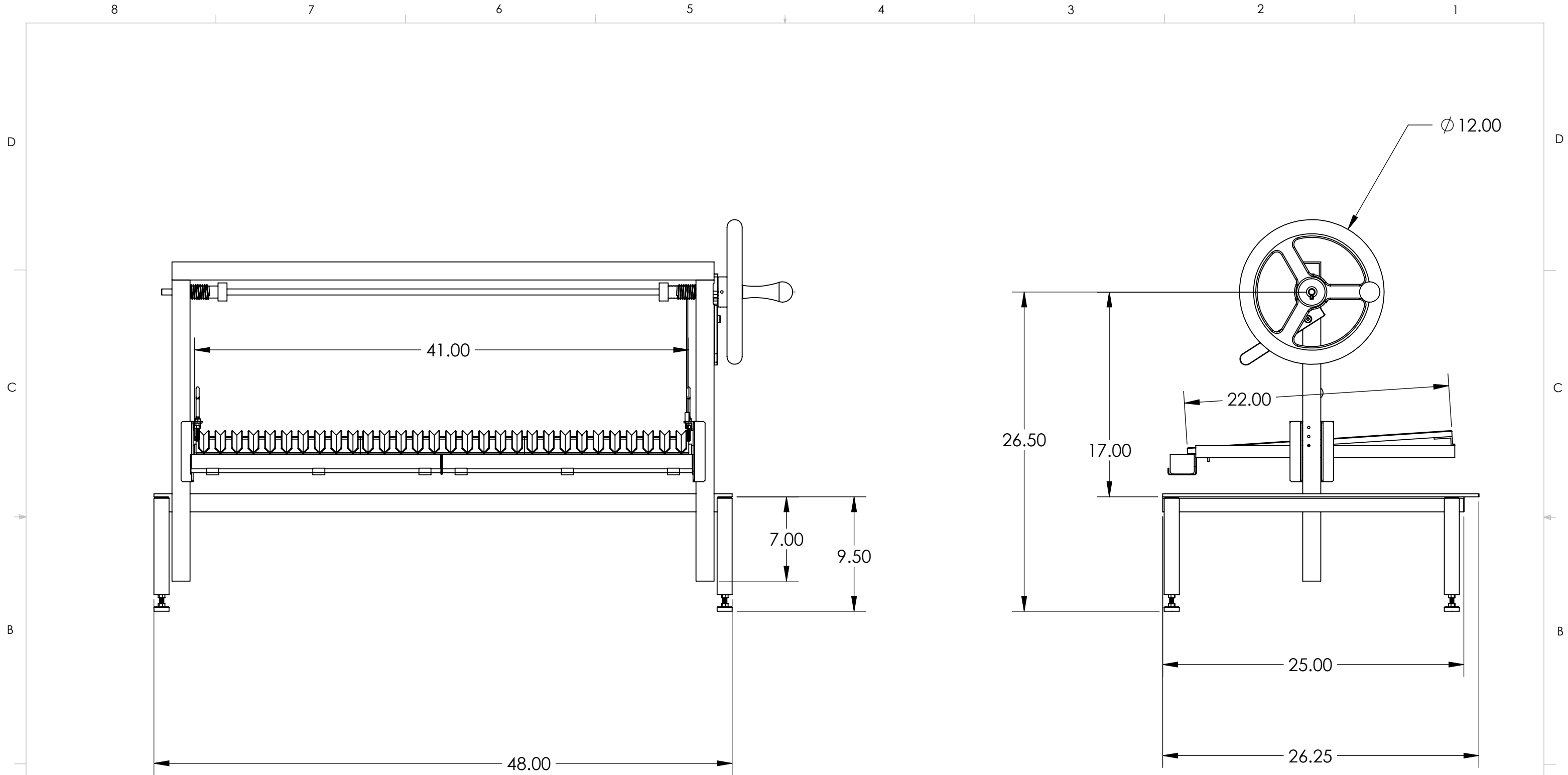

| | | | | | | |
|--|--|---|------|---|----------|--------------|
| UNLESS OTHERWISE SPECIFIED: | | NAME | DATE | Gaucha Grills | | |
| DIMENSIONS ARE IN INCHES | | DRAWN | | | | |
| TOLERANCES: | | ENG APPR. | | TITLE: INSERT. LARGE, LEG MOUNT, RH | | |
| ONE PLACE DECIMAL ±.1 | | MFG APPR. | | | | |
| TWO PLACE DECIMAL ±.01 | | Quantity | | SIZE | DWG. NO. | REV |
| THREE PLACE DECIMAL ±.005 | | Heat Treatment and Special Handling: | | B | GI5-4C-2 | - |
| ANGULAR ±.5° | | | | SCALE:1:1 | | SHEET 2 OF 2 |
| SURFACE ROUGHNESS 125µin | | | | | | |
| INTERPRET GEOMETRIC TOLERANCING PER: ASME Y14.5M-1994 | | | | | | |
| MATERIAL | | | | | | |
| FINISH | | | | | | |
| DO NOT SCALE DRAWING | | | | | | |

THIS DRAWING IS THE PROPERTY OF ARGENTUM OUTDOOR CREATIONS, LLC. REPRODUCTIONS SHALL BE FOR QUOTATION, MANUFACTURING OR PURCHASING PURPOSES ONLY. RELEASE OF DRAWINGS TO OTHER CONCERNS DOES NOT CONSTITUTE LICENSING IN ANY WAY.

8 7 6 5 4 3 2 1

8 7 6 5 4 3 2 1

D
C
B
A

D
C
B
A